

CLIP FERRITE CORE FOR FLAT CABLE / FI TYPE

APPLICATIONS

Cables between pc boards and data connectors, floppy disk and hard disk ribbon cables, printer cables, retrofit, auxiliary EMI attenuation, internal ribbon cables with series digital signal busses



MATERIAL

B8 B10 B15

ORDERING CODE

FI 63.5 x 28.5 x 12.7 N1 B8

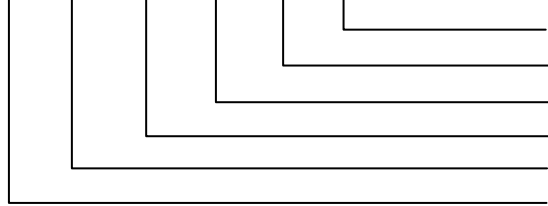

Material
CLIP
B
D
A
Product Symbol

CHIP : N1- Nylon Clamp
N2- Nylon Clamp
N3- Nylon Clamp
M / M1- Metal Clamp
M2- Wire Clamp

CLIP MATERIAL

N1,N2,N3: Nylon-66(UL)
Flame Class: 94V-2

M1: Spring Steel
Nickel Coating

M2: Piano wire
Nickel Coating

M: SK5 WITH HEAT TREATMENT

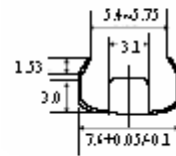
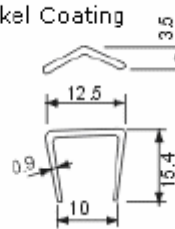
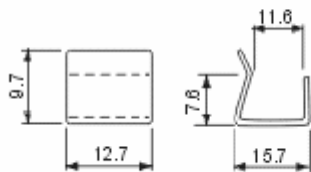

SHAPES

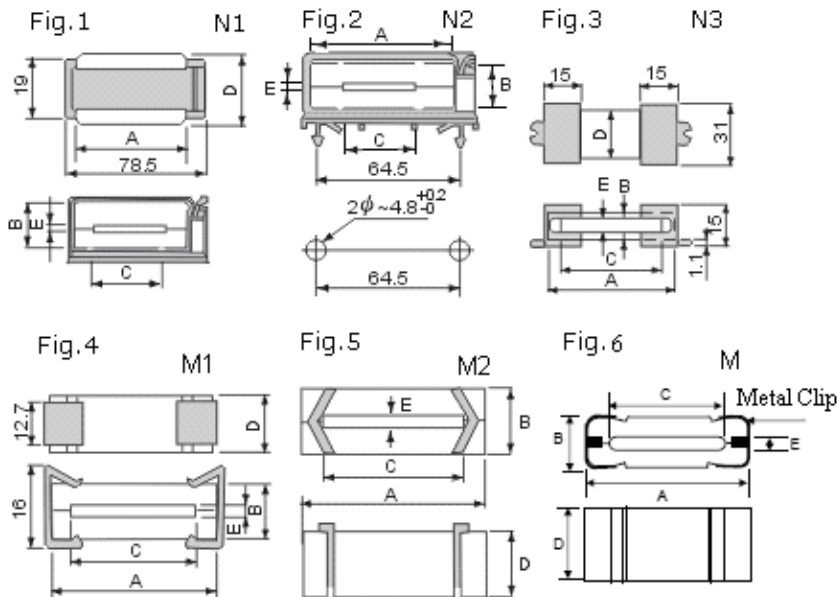

CORE MASTER ENTERPRISE CO., LTD.



<http://www.coremaster.com.tw>

CLIP FERRITE CORE FOR FLAT CABLE / FI TYPE

DIMENSIONS: UNIT: mm

Part No.	Fig.	A	B	C	D	E	Impedance(Ω)Min	
							25MHz	100MHz
FI 29x15x8 M	6	29.0±0.8	8.0±0.4	22.0±0.8	15.0±0.4	2.0+0.5/-0.3	30	80
FI 38x15x12.7 M2	5	38.0±1.0	12.7±0.5	26.6±0.7	15.0±0.4	1.6±0.4	40	115
FI 38x25.4x12.7 M1	4	38.0±1.0	12.7±0.5	26.6±0.7	25.4±0.7	1.6±0.4	75	140
FI 45x15x12.7 M2	5	45.0±1.0	12.7±0.5	34.4±0.7	15.0±0.4	1.6±0.4	40	90
FI 45x28.5x12.7 M1	4	45.0±1.0	12.7±0.5	34.4±0.7	28.5±0.7	1.6±0.4	70	140
FI 45x28.5x12.7 N3	3	45.0±1.0	12.7±0.5	34.4±0.7	28.5±0.7	1.6±0.4	70	140
FI 55.1x15x12.7 M2	5	55.1±1.0	12.7±0.5	43.7±1.0	15.0±0.4	1.6±0.4	40	105
FI 55.1x28.5x12.7 M1	4	55.1±1.0	12.7±0.5	43.7±1.0	28.5±0.7	1.6±0.4	65	140
FI 55.1x28.5x12.7 N3	3	55.1±1.0	12.7±0.5	43.7±1.0	28.5±0.7	1.6±0.4	65	140
FI 63.5x15x12.7 M2	5	63.5±1.2	12.7±0.5	52.0±1.0	15.0±0.4	1.6±0.4	40	95
FI 63.5x28.5x12.7 M1	4	63.5±1.2	12.7±0.5	52.0±1.0	28.5±0.7	1.6±0.4	60	150
FI 63.5x28.5x12.7 N1	1	63.5±1.2	12.7±0.5	52.0±1.0	28.5±0.7	1.6±0.4	60	150
FI 63.5x28.5x12.7 N2	2	63.5±1.2	12.7±0.5	52.0±1.0	28.5±0.7	1.6±0.4	60	150
FI 63.5x28.5x12.7 N3	3	63.5±1.2	12.7±0.5	52.0±1.0	28.5±0.7	1.6±0.4	60	150
FI 76.2x28.5x12.7 M1	1	76.2±1.5	12.7±0.5	65.2±1.2	28.5±0.7	1.6±0.4	60	190
FI 76.2x28.5x12.7 N3	3	76.2±1.5	12.7±0.5	65.2±1.2	28.5±0.7	1.6±0.4	60	190

FI 38x25.4x12.7

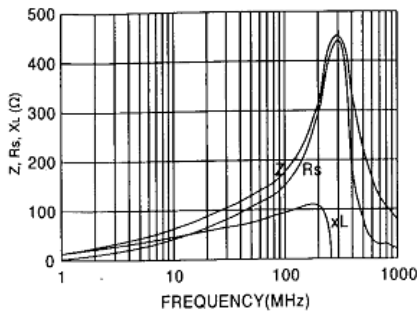

FI 45x15x12.7

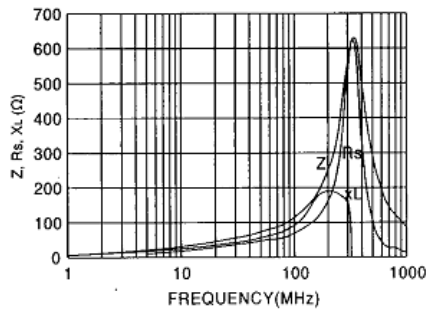

FI 55.1x15x12.7

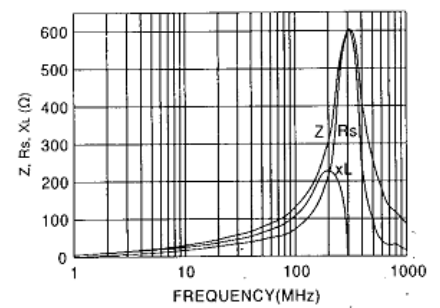

FI 63.5x15x12.7

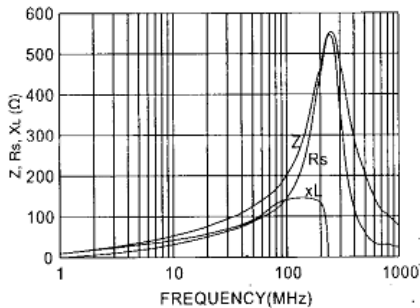

FI 63.5x28.5x12.7

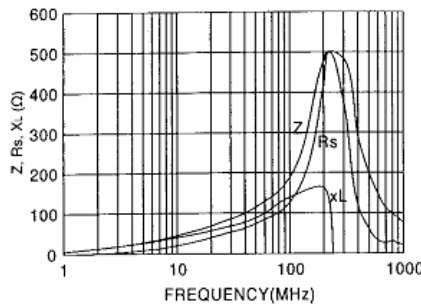

FI 76.2x28.5x12.7

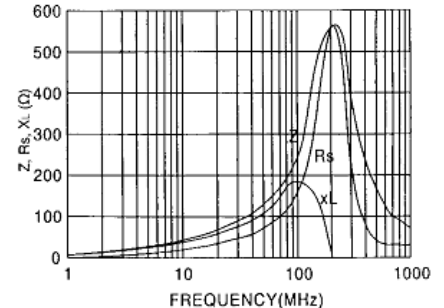

CORE MASTER ENTERPRISE CO., LTD.



<http://www.coremaster.com.tw>